



Damage to vacuum pumps through incorrect assignment

Vehicle	Product: Vacuum pump	
	PIERBURG No.	O.E. No.*
VW Transporter LT, T4 (pickup, window van, panel van, California) Engine code: AAB	7.22300.62.0	075 145 100 ; 075 145 101; 075 145 101 A
	7.22300.69.0	074 145 100 A

Due to a change of the cylinder head in the case of the VW T4 engine with engine code AAB the vacuum pump has frequently been incorrectly assigned.

! Mounting the wrong pump will “immediately”, upon starting the engine for the first time after installing the vacuum pump, cause the pump casing (see Fig. 1) to break or even the camshaft may break thereby resulting in severe and expensive engine damage.



Fig. 2: Vacuum pump comparison



Fig. 1: Broken pump casing

Complaints relating to these pumps due to being incorrectly installed are not accepted.

	7.22300.62.0	7.22300.69.0
Replacement for	7.22300.12.0	7.22300.19.0
Year of manufacture	to 5/1994	from 5/1994
Vehicle identification number	to 70-R-180 000	from 70-R-180 001
VW part number	075 145 100, 075 145 101 075 145 101 A	074 145 100 A
VW cylinder head No.	074 103 351 A	074 103 351 D
MSI cylinder head No.	50 003 101	50 003 113
Cylinder head cover surface	11 bores; Ø 5mm	no bores
PIERBURG tappet rod number	3.52124.06.0	3.52124.05.0
VW tappet rod number	075 145 307	074 145 307 B
Tappet rod length	71,0 mm	67,5 mm

In order to prevent damage, a precise check of the vehicle data is essential. We recommend to check in any case the assignment through the vehicle identification number!

! Under all circumstances check

- vehicle identification number
- registration date and/or
- part number of the old pump!

The right of changes and deviating pictures is reserved. Assignment and usage, refer to the each case current catalogues, TecDoc CD respectively systems based on TecDoc.
 * The reference numbers given are for comparison purposes only and must not be used on invoices to the consumer.



Proper installation

During installation work the cam of the camshaft which drives the vacuum pump must be located at the opposite side of the intermediate tappet rod (see Fig. 3) so as to be able to install the pump under a slight pre-tension only (gap of 2 mm max.):

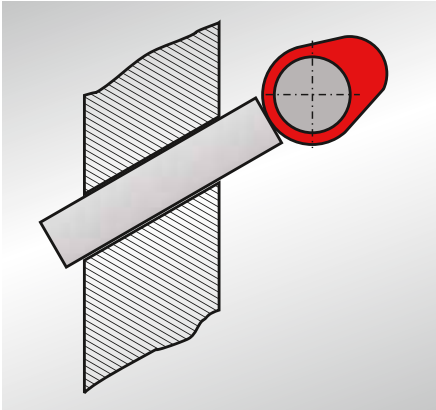

Fig. 3: Position of the camshaft during installation

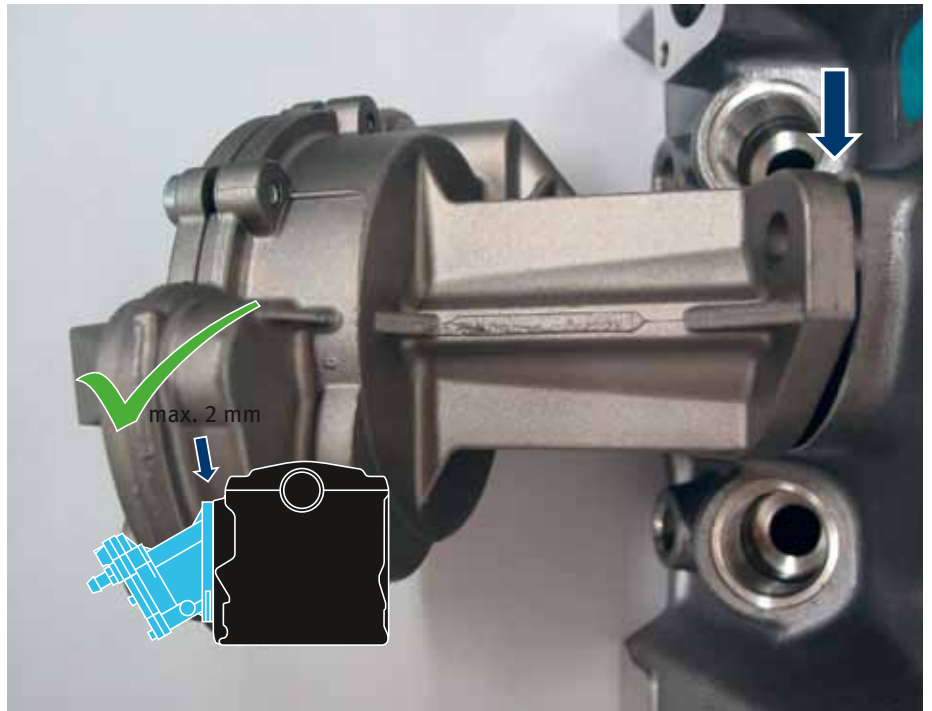

Fig. 4: Installation with correct assignment

Wrong assignment – installation not possible

If the vacuum pump cannot be pressed onto the flange without exerting a significant amount of force (gap 5 mm approx.) although the cam is located at the opposite side of the intermediate tappet rod you can be sure that the assignment is wrong.

- !** Under all circumstances check
- vehicle identification number
 - registration date and/or
 - part number of the old pump!

- !** Never try to resolve this problem by modifying the intermediate
- tappet rod (by grinding, for example)

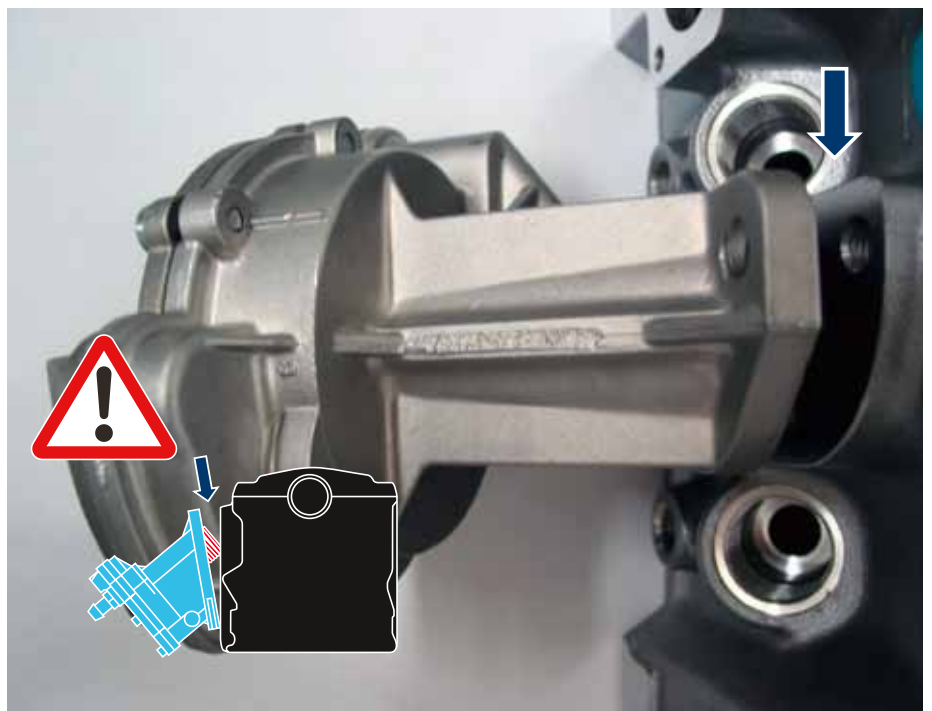

Fig. 5: In the case of a wrong assignment, proper installation will not be possible